



agnati
impianti per cartone ondulato
corrugating machinery

Single Facer upgrade

COMPACT90

Upgrade UG-500062

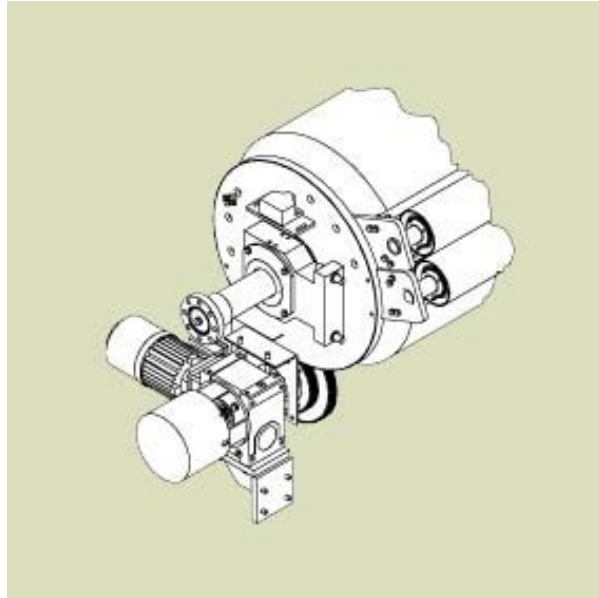
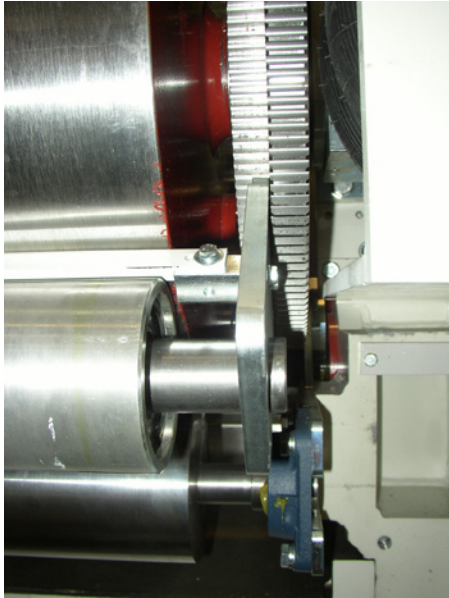

WRAP ROLLS FOR THE ON BOARD PRECONDITIONER

AUTOMATIC WRAP CONTROL RELATED TO THE SPEED, OR – AS OPTION – TO THE PAPER TEMPERATURE
NO OVERHEATING OF THE MEDIUM PAPER
FLUTING PREHEATING FROM 0° (NO CONTACT) UP TO 180°

The wrap rolls for the on board preconditioner provide the advantages of:

- > No overheating of the medium paper due to the automatic wrap control, relative to the speed and – as option – to the paper temperature.
- > The fluting is wrapped by two separate wrap rolls that ensure that the fluting, if necessary, to have no contact with the preconditioner - wrap angle 0° - or to be preheated gradually up to the maximum wrap angle of 180°.

Supply:

Two wrap rolls.

Gearmotor and drive control for automatic positioning.

Catwalk for the replacement of the existing one.

For Compact90 single facer equipped with Hitachi PLC: 10" Touch Screen to preset – record – display the speed curve.

For Compact90 single facer equipped with Allen Bradley PLC: Software Integration to the existing Control System to preset – record – visualize the speed curve.



Single Facer upgrade

COMPACT90

Upgrade UG-500062

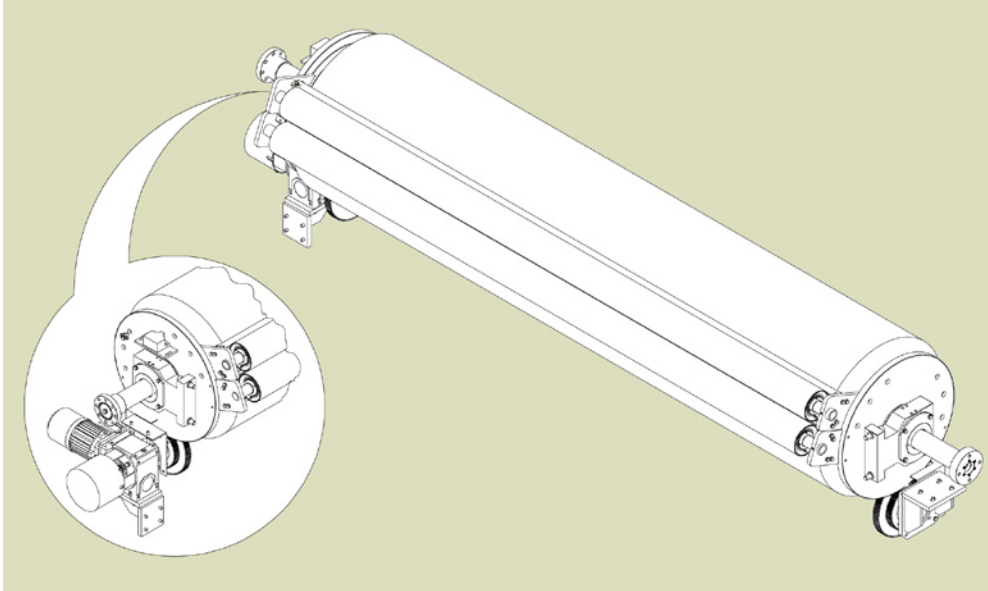

Sketch of wrap rolls

Note:

The installation requires Agnati service technicians (1 mechanic and 1 electrician) for 3 full days. Two mechanics and one electrician are to be supplied by the customer for the installation.

Downtime:

No downtime for adjustments during start-up.

Warranty:

One year on components.

This retrofit is not valid for the Compact90 Single Facer with Combi System or 600mm diam. preconditioner.



agnati

Impianti per cartone ondulato - corrugating machinery

Agnati S.r.l. - 20059 Vimercate (Mi) Italy Via Lecco, 72 - T +39.039 6087 1 - F +39.039 6087 221 - E info@bpagnati.com - W www.bpagnati.com